



A

DRILLING

## GEN2 T-A Drill Inserts

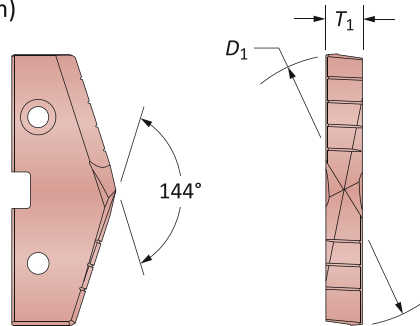

7 Series | HSS | Diameter Range: 3.508" - 4.000" (89.10mm - 101.60mm)



B

BORING

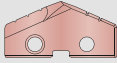
HSS Inserts – Super Cobalt | HSS

| Fractional Equivalent | Insert     |          |       | Super Cobalt Part No.   | HSS Part No.   |
|-----------------------|------------|----------|-------|---|--|
|                       | $D_1$ inch | $D_1$ mm | $T_1$ | <br>AM200® | <br>TiN |
| 3-17/32               | 3.5313     | 89.69    | 7/16  | 457H-0317   | 437T-0317  |
| -                     | 3.5433     | 90.00    | 7/16  | 457H-90   | 437T-90  |
| 3-9/16                | 3.5625     | 90.49    | 7/16  | 457H-0318   | 437T-0318  |
| 3-19/32               | 3.5938     | 91.28    | 7/16  | 457H-0319   | 437T-0319  |
| -                     | 3.6221     | 92.00    | 7/16  | 457H-92   | 437T-92  |
| 3-5/8                 | 3.6250     | 92.08    | 7/16  | 457H-0320   | 437T-0320  |
| 3-21/32               | 3.6563     | 92.87    | 7/16  | 457H-0321   | 437T-0321  |
| 3-11/16               | 3.6875     | 93.66    | 7/16  | 457H-0322   | 437T-0322  |
| -                     | 3.7008     | 94.00    | 7/16  | 457H-94   | 437T-94  |
| 3-23/32               | 3.7188     | 94.46    | 7/16  | 457H-0323   | 437T-0323  |
| 3-3/4                 | 3.7500     | 95.25    | 7/16  | 457H-0324   | 437T-0324  |
| -                     | 3.7795     | 96.00    | 7/16  | 457H-96   | 437T-96  |
| 3-25/32               | 3.7813     | 96.04    | 7/16  | 457H-0325   | 437T-0325  |
| 3-13/16               | 3.8125     | 96.84    | 7/16  | 457H-0326   | 437T-0326  |
| 3-27/32               | 3.8438     | 97.63    | 7/16  | 457H-0327   | 437T-0327  |
| -                     | 3.8583     | 98.00    | 7/16  | 457H-98   | 437T-98  |
| 3-7/8                 | 3.8750     | 98.43    | 7/16  | 457H-0328   | 437T-0328  |
| 3-29/32               | 3.9063     | 99.22    | 7/16  | 457H-0329   | 437T-0329  |
| -                     | 3.9370     | 100.00   | 7/16  | 457H-100  | 437T-100   |
| 3-15/16               | 3.9375     | 100.01   | 7/16  | 457H-0330   | 437T-0330  |
| 3-31/32               | 3.9688     | 100.81   | 7/16  | 457H-0331   | 437T-0331  |
| 4                     | 4.0000     | 101.60   | 7/16  | 457H-0400   | 437T-0400  |

C

REAMING

D

BURNISHING

E

THREADING

X

SPECIALS

Inserts sold in quantities of 1

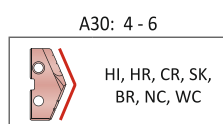
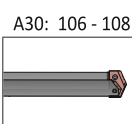
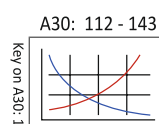

Coatings not listed above  
can be supplied as  
non-stocked standards.  
Process fees apply. →

|                  |                    |
|------------------|--------------------|
| TiN = 457T-XXXX  | TiAlN = 457A-XXXX  |
| TiCN = 457N-XXXX | AM200® = 457H-XXXX |